



*ETMCon 2012*  
Energy Technology and Management Conference 2012



**ETMCon 2012**

**Energy Technology and Management Conference 2012**

**5-7 September, 2012**

**Conference Centre, University of Ibadan**

**Theme: Energy Technology & Management for Sustainable  
Development**

**Conference Programme of Events and Book of Abstracts**



LIST OF AUTHORS

- Oladosu A.A, Odesola I.F and Olawore A.S* Analysis Of Two Dimensional Heat Transfer Problem Using Spreadsheet Approach
- Adeyefa. O.A and Oluwole.O.O* Insulation Thickness Modelling for Boil-Off Gas Reduction in Liquified Natural Gas Spherical Storage Pressure Vessels
- Adamu S. S and Popoola K. A.* Reliability Assessment Of Electric Power Distribution System: A Case Study Of Lokoja 11 Kv Distribution Network
- Adamu S. S and Adamu M* Analysis Of Energy Losses In Power System Networks: A Case Study Of Transmission Sub-Region, Kano, Nigeria
- Adamu, A. A. and Enaburekhan, J. S.* Experimental And Numerical Investigation Of The Wake Of Wind Turbine With Convergent Nozzles (Experimental Results)
- Adamu, A. A. and Enaburekhan, J. S.* Experimental And Numerical Investigation Of The Wake Of Wind Turbine With Convergent Nozzles (Computational Fluid Dynamics Results)
- Oririabre, Idise J. and Odesola, I. F* Magnetic Fuel Energizer: Its Prospects and some Niggling Issues.
- Ibraheem T.B, Adeleke D.A, Ibrahim A.I, Ajeigbe A.O and Ojo D.T* Energy Technology and Management for Sustainable Development.
- Isa garba* Experimental investigation of force convection solar dryer



- O.A. Akintunde and Simolowo O. E* Development of Software Algorithm for Energy Modeling and Forecasting.
- Adediran A.A. and Simolowo O.E.* Assessment Of Household Energy Efficiency In Ibadan, Nigeria.
- Elusakin J. E., Ajide O. O., Salau T.A.O. and Idowu O. G.* Energy Audit of Commercial Buildings (A Case Study of Global Fleet Oil Ltd. And National Mirror Houses).
- O.J Oyebode* Energy Saving and Management in Transportation Sector through Biogas Technology.
- A. L. Amoo, Y. S. Haruna and S. Babawuro* Cogeneration: A Power Management Scheme For Cement Industry In Nigeria.
- Oviroh, P.O, Idusuyi, N and Ajayi O.K* Cost And Environmental Benefits Of A Solar Powered Base Transceiver Station.
- G. T. Adewoye and O. S Ismail* Analyses on Proper Material Selection to Mitigate Problems Facing Thermal Cladding and Insulation of Fluid Flow in Pipes.
- G. E. Umukoro and O. S. Ismail* Effective Utilization of Natural Gas: The Nigerian Scenario.
- Onibon-oje O.O, Ismail:O.S. and Ajide O.O.* Assessment of Biofuel Opportunities in Nigeria: A Case Study of Southwest, Nigeria.
- Adediran A.A. and Simolowo O.E.* Economics of Electricity self-generation by the Telecommunication Industry in Nigeria



- Alabi A., G.O. Idowu and Ajide O.O* Effects Of Frequency Control On Power System Stability.
- Daramola, O.M. and Ajide O.O.* Reduction Of Technical And Commercial Losses In Electric Power Distribution In Nigeria
- G.O. Idowu., Ajide O.O., Oluwole O.O., Elusakin J.E. and Alabi A.* Effect of Energy Utilization On Economic Growth In Nigeria.
- K.M. Odunfa, T.O. Ojo and V.O. Odunfa* Energy Efficiency in Building Part I.
- K.M. Odunfa, A. A. Dare and O.A. Adeaga* Energy Efficiency in Building Part II.
- Adewole O. S. and O. S. Ismail* Evaluating The Prospect Of Generating Biogas From Human Faeces For Cooking In The University Of Ibadan Halls Residence.
- T.O. Raji , O.M. Oyewola, and T.A.O. Salau,* Effect Of Particle Size On Combustion Of Coconut Shell In A Bubbling Fluidized Bed Combustor
- K.M. Odunfa and T.O. Ojo* Energy Efficiency in Building (A case study of Three Lecture Theaters U.I)
- Elusakin J.E., Diji C.J., Ajide O.O. and Adegbola A.A.* Nigerian Content Act and Its Impact on the Petroleum Industry In Nigeria
- Fadimu Oluwaseun* An Optimal Renewable Energy Mix: A Review of Selected States In Nigeria.
- Effiom E. E., Odesola I. F. and Ajide O. O.* Impact Of New Electricity Tariff (MYTO II) On The Nigerian Economy



- K.M. Odunfa and S.A. Komolafe* Design And Development Of An Energy Tool For Solar Pv Stand-Alone Street Lighting Installation.
- M.O Durowoju, K. O Oladosu and O.A Adeleke* Energy Auditing in a Production Firm: A Case Study of Bread Baking.
- Chapi, S.P, Omoregbee Henry O and Amori, A.A* Solar Energy, A Panacea To Rural Electrification Utilisation: A Case Study Of Nigeria.
- Oluwole.O and Emagbetere E* Finite Element Analysis of Von-mises Stress in Ellipsoidal and Circular Cylindrical Petroleum Tankers.
- Abiodun, Felix* Development of Nuclear Energy in Nigeria: Prospects and Challenges Prospects and Challenges.
- N.A. Adewole, M.O. Oyewola, T.A.O. Salau, R.O. Bello and T.O. Raji* Preliminary Investigation of Emission Characteristics of Shaving from Three Wood Species Utilized for Furniture Production in Ibadan, Oyo State.
- Chapi, S.P and Omoregbee Henry O* Alternate Energy Sources For CI Engines: A Focus On Nigeria.
- Alabi, S.A and Diji, C.J* Alternative Uses of Biomass for Electricity Production in a local Nigerian Community.
- Ganiyu, H. and Diji, C.J.* Energy Auditing of a Typical Residential Building in Ibadan Metropolis.
- O.A. Okunola, D.A. Fadare and A.O. Oni* Energy Utilization And Carbon Emission Signature Of University Of Ibadan Water Treatment Plant.



- Ololade Oyeropo Babarinde and David Abimbola Fadare* On the Evaluation of Energy Requirements in Turning of Steel, Aluminium and Brass.
- Rotimi Abiodun Afe and David Abimbola Fadare* An Assessment of Economics Variability Of Solar-Powered Vsat For Rural Telephone System In Nigeria.
- A.A. Dare, O.A. Adeaga K.M. Odunfa and O. Olayiwola* Cheap And Local Production Of Solar Lantern In Nigeria.
- Olugasa Temilola and E.J. Johnson* A Case Study of Methane Gas Generation From Swine Dung At Cuttington University Farm, Suakoko, Liberia
- Obagunle, R.G and Adeaga, O.A* Design and Construction Of A Charge Controller In A 2kv Solar Electrification
- Odia J., Dare A. A. and Emagbetere E.* Assessment Of Household Energy Utilized For Cooking In Ikeja Of Lagos State, Nigeria.
- Alamu, O.J.* Development of empirical relationship between specific gravity and temperature for palm kernel oil biodiesel



**Preliminary Investigation of Emission Characteristics of Shaving from Three Wood Species Utilized for Furniture Production in Ibadan, Oyo State**

**N. A. Adewole<sup>1</sup>, M. O. Oyewola<sup>2</sup>, T. A. O. Salau<sup>2</sup>, R. O. Bello<sup>1</sup> and T. O. Raji<sup>2</sup>**

<sup>1</sup>Department of Agricultural and Environmental Engineering, University of Ibadan

<sup>2</sup>Department of Mechanical Engineering, University of Ibadan

**ABSTRACT**

Carpentry workshop is among the prominent and active components of the Nigerian wood industrial sector. The activity in carpentry workshop inevitably generates different categories of wastes. Shavings is among the wood wastes generated in large quantity and the common means of disposing it in major town like Ibadan in Oyo State is by combusting. Large percentage often finds its way to household where it's often used to subsidize fuel for domestic cooking. However, this means of disposal may be prone to health hazard due to the emission released during its combustion. This work examines the combustion characteristics of three typical wood species that are commonly use for furniture production in Ibadan, Oyo state. The species were combusted in Bubbling Fluidized Bed (BFB) combustion under various operating conditions. The result shows that Carbon monoxide (CO) emission is pronounced in the combustion of all the wood species. In all the three cases, *Milicia excelsa* (Iroko) and *Tectona grandis* (Teak) have the lowest and highest CO emission respectively. It is suggested that if this waste must be used as fuel for domestic cooking, appropriate technology must be employed especially where low combustion temperature is desirable. However, proper disposition of this waste should be encouraged.

**Keywords:** Wooden furniture, Waste disposal, Wood shavings, Emission characteristics,

**INTRODUCTION**

As at 2002, about three billion people in developing nations were said to have relied on biomass in the form of wood, charcoal, and other agricultural residues as source of their domestic cooking fuel (Ezzati and Kammen, 2002). Nigeria's population was estimated as 140 million according to the population census figure released in 2006 and about 70% of this population lives below poverty level (Onibokun, and Kumuyi, 1996; NPC, 2006,). By 2012, the population of Nigerian relying on biomass as main source of domestic cooking fuel may have increased tremendously in view of increase level of poverty and un-ending population growth. Cooking will most often carried out indoors and in environments that lack proper ventilation by this considerable



It is for this reason that this study was initiated to examine the emission characteristics of wood waste from harvested carpentry workshop in Ibadan in the form in which users often utilized it as fuel for indoor cooking with a view to ascertain their health hazard on comparison basis with another leading alternative biomass that are used for same purpose in both rural and urban areas of Ibadan, Oyo State, Nigeria.

## MATERIALS AND METHODS

The biomass fuel that was used for this experiment was produced in the Wood Processing Laboratory in the Department of Agricultural and Environmental Engineering, Faculty of Technology, University of Ibadan. Details of the biomass are presented in Table 1 while their samples are shown in Plate 1. For an uneven character fuel that is often difficult to feed, manual feeding chute was enabled for feeding. The manual feeding chute is indicated in Figure 1 and the wood shavings samples were fed in batches.

**Table 1: Characteristics of the Biomass Fuel Used**

Parameters	<i>Anigeria Robusta</i> (Landosan)	<i>Tectona grandis</i> (Teak)	<i>Millicia excelsa</i> (Iroko)
Bulk density (kg/m <sup>3</sup> )	85	115	100
Feed rate by batch feeding (kg/hr)	2.12	2.18	2.3
Moisture content	Green	Green	Green
Description	uneven shaving	uneven shaving	uneven shaving

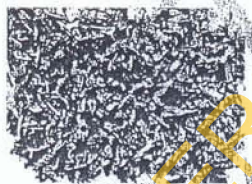

a.) Teak

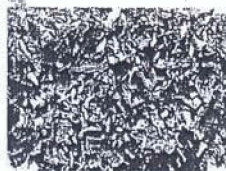

b) Landosan

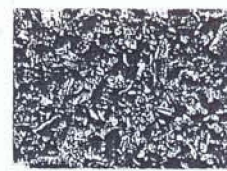

c) Iroko

**Plate 1: Sample of the Shavings from the Three Wood Species Used for the Study**

The experimental model BFBC employed for this investigation has been described in details in another article (Raji *et al*, 2011). It consist of five 150mm diameter stainless steel modules joined together to form the combustor body. The whole arrangement is partitioned into lower and upper section; module 1 and 2 forms the lower section while the remainder fully assembled form the upper





section as shown in Figure 1. The objective of the partitioning is to enable observation of the fluidization process and the combustion process at start up or anytime necessary as well as to enable determination of the fuel feed rate and the bubbling regime at room temperature. The distributor plate sandwiched between module 1 and 2 is fabricated from 10mm thick stainless

ETM CON 2012  
UNIVERSITY OF IBADAN LIBRARY

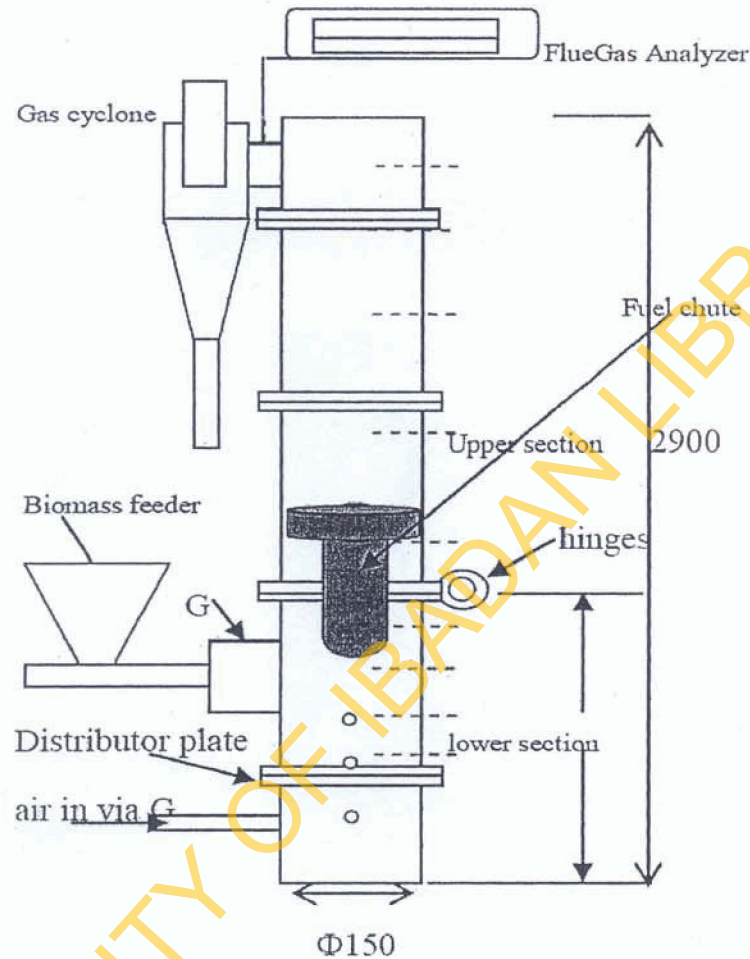

----- nine thermocouples (T1 – T9) arranged axially along the combustor body.  
G Fluidizing air pre-heater/Biomass feeding pipe's cooling attachment.  
Lower section is module 1& 2  
Upper section is module 3, 4& 5  
o Pressure Tap

Figure 1: Schematic Drawing of the Developed BFBC.

steel plate bearing 13 standpipes. Each standpipe has forty 1.5mm holes drilled radially around it. Silica sand, mean diameter of 500micron is employed as the inert bed material. Supply of the test



fuel from the hopper to the inert bed was done with a conveyor-screw type biomass feeder equipped with an infinitely variable speed gear motor; the feeder discharge is located 400mm above the distributor plate. At the junction between biomass feeding pipe and the combustor body a fluidizing air pre-heater / biomass feeding pipe's cooling attachment was provided. This was to prevent the biomass from burning before entering the fluidized bed and to utilize the heat energy that would otherwise be wasted and consequently cut down the fuel usage per useful energy generated, this unit is shown as G in Figure 1. To prevent excessive heat loss ceramic insulation of thickness 75mm secured by means of 0.5mm galvanized steel plate was used to cover the combustor body from the distributor plate to the last module. The BFBC was also equipped with an inert bed temperature regulating unit (ITRU), which enables the capability to fix the inert bed temperature to any specific value during the experimental runs. It does this by switching off and on the fuel/ air supply as soon as the pre-set inert temperature is reached. The frequency of switching is an indication of the intensity of combustion taking place within the inert bed; the higher the intensity the higher the frequency; converse is the case when there is no switching off.

With the control switched on, fluidization air via the centrifugal blower was tuned to achieve a bubbling inert bed condition; at this point propane gas passed through 8mm diameter stainless steel pipe located 10mm above the distributor plate was switched on and ignited; allowing the inert bed temperature ( $T_b$ ) to rise to 600°C, this took about 29 minutes. Prior investigations had revealed that the more turbulent the inert bed during preheating the faster the specified inert bed temperature is achieved. The wood was manually fed into the inert bed via the fuel chute. The composition of the flue gas ( $CO$ ,  $CO_2$ ,  $NO_x$ ,  $SO_x$ ), and Excess Air (EA) were monitored using BACARACH PCA 3 flue gas analyser connected to a port located after the gas cyclone separator inlet; temperatures were taken from nine zones, located along the combustor height via Type K thermocouples fitted to the first 8 zones and in-built temperature sensors of the BACARACH PCA 3 records the temperature in the ninth zone. The thermocouple for zone 2, inert bed upper region was connected to the ITRU and this temperature ' $T_2$  or  $T_b$ ' in all the experimental runs was set as 750°C. This temperature is taken by the thermocouple located 20cm above the distributor plate.  $T_1$ ,  $T_2$ ,  $T_3$ ,  $T_4$ ,  $T_5$ ,  $T_6$ ,  $T_7$ ,  $T_8$ , and  $T_9$  are located 10cm, 20cm, 35cm, 80cm, 120cm, 160cm, 200cm, 240cm and 260cm respectively above the distributor plate. The results of the experimental runs for different particle sizes are presented next.



## RESULTS AND DISCUSSION

Combustion of all the waste samples was characterized by low feed rate (<2.4kg/hr) because of low bulk density of the wood waste samples. By inference this signifies low energy density and this coupled with fact that the BFBC is designed for fuel feed rate of 4kg – 6kg/hr had a significant impact on the thermal and emission results as well as the course of the investigation. For each of the fuel, experimental runs were planned for five EA (20%, 40%, 60%, 80% and 100%). However due to the maximum possible feed rate for the wastes, which ranges from 2.1-2.3kg/hr, combustion was done at high EA, most of the time at EA>150%. The use of batchloading prove quite fruitful, since due to this the EA goes down at the point of loading thereby enabling obtaining results for EA=100% for each of the samples as shown in Table 2

Emission value obtained were converted to emission value at 6% of oxygen in the flue gas, and plotted against the percentage of EA. Interestingly, all the wastes show a similar pattern.

**Table2: Axial Temperature Distribution and Emission Reading at EA =100% for the three Wood Species and Palm Kernel Shell**

Run	IROKO	LANDOSAN	TEAK	PKS [b]
Temp/EA	108%	110%	109%	100%
T1	320	165	138	662
T2	685	650	690	750
T3	630	618	662	730
T4	603	589	605	523
T5	581	584	588	436
T6	539	550	548	404
T7	495	529	536	363
T8	419	490	492	332
T9	227	391	388	241
CO(6)	859	1250	1420	91
CO <sub>2</sub> (6)	10.3	10.1	10.2	10
NO <sub>x</sub> (6)	-----	-----	-----	175
SO <sub>x</sub> (6)	130	-----	-----	54

----- = value not displayed (O<sub>2</sub> >16% in flue gas)



**Observations**

i) The bulk density had significant impact on the temperature profile; the particle being very light are easily blown to the freeboard zone where they burn therefore the higher freeboard temperature obtained for the three wood waste in comparison to PKS is shown in Figure 2.

ii) The bulk density also had drastic impact on the bed temperature; the result shows that the preset temperature (T2) of 750C could not be achieved for the three wood wastes an indication of minimal char combustion / low combustion intensity in the bed region. Also, T1 for the wood chaffs << T1 (PKS) is shown in Figure 2.

iii) CO in the flue gas was also disproportionately high compare to PKS. This indicate significant heat loss due to incomplete combustion and hence lower combustion efficiency when compare to PKS at equivalent EA.

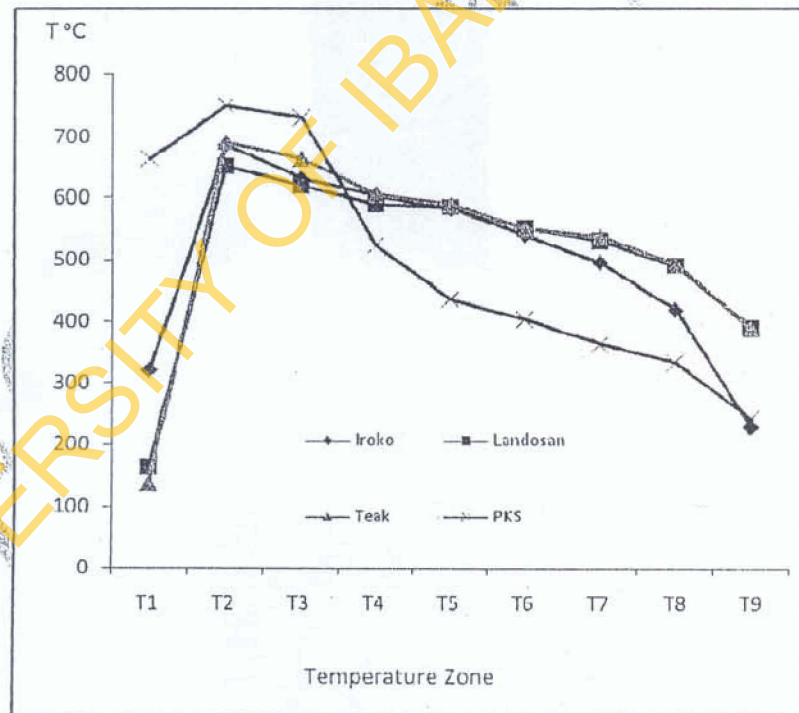

Figure 2: Temperature Profile of Iroko, Landosan, Teak Compare to PKS at EA= 100%

**Pollutants Emission**



2. Teak showed the highest peak temperature while Landosan showed the lowest peak temperature reflecting their heating values. It is therefore recommended that wood chips in view of higher bulk density and hence higher energy density should be used for the experiment.

3. The wastes have high Carbon monoxide (Co) emission as compared with Palm Kernel Shell (PKS) suggesting that they possess high risk to the environment. It should be noted that since the Excess Air (EA) condition during this experimental investigation is akin to the prevailing condition during open air burning of this wastes, the CO emission is most likely to be similar. Therefore, it may be appropriate to suggest that proper disposition of these wastes should be encouraged.

4. However, whenever it is expedient to conduct open air burning of the shavings from Iroko, Landosan and Teak, as in the case of using to subsidize the domestic cooking fuel, it should not be done indoor but at a sufficiently distance from living area. Meanwhile wood shavings from these wood species may be used as fuel if appropriate technology is employed in their processing such as densification at a temperature above 300°C.

#### REFERENCES

- Abudullahi, A.A. 2003. Wood Resources as a Raw Material for the Wood Products Industries. Lecture Delivered as Part of a Three-Day Technical Seminar on Investment in Wood Manufacturing, SMEs. Organized by UNIDO. 19pp.
- Adewole A.N and A. O. Olorunnisola, 2010. Characteristics of Classroom Chairs and Desks in Use in Senior Secondary Schools in Ibadan, Oyo State, Nigeria. *Journal of Emerging Trends in Engineering and Applied Sciences* 1:2.  
<http://jeteas.scholarlinkresearch.org/issuesview.php>
- Adewole A. N. and Bello R. O. 2012. Appraiser of Roadside Carpentry Workshop In Iwo, Osun State, Nigeria. Published in Conference Proceedings of the 4th International Conference On Engineering Research & Development: Advances In Engineering, Science & Technology (ICERD2012), held from 4 – 6 September 2012 in University of Benin, Nigeria. 10pgs
- Anon- 1998. Wood Furniture Manufacturing – Compliance and Pollution Prevention Workbook. Pacific Northwest Pollution Prevention Resource Center. Accessed on May, 2012.  
<http://www.pprc.org/pubs/factsheets/woodfurn.html>



- Raji, T.O, Oyewola, O.M, Salau, T.A.O., On combustion of 'as received' Palm Kernel Shell in a Bubbling Fluidized Bed Combustor, Proceedings of the 9th International Conference on Heat Transfer, Fluid Mechanics, and Thermodynamics, Malta, July 2012.
- S.A.Oka, 2004. Fluidized bed combustion. Marcel Dekker, New York.

UNIVERSITY OF IBADAN LIBRARY  
ETMCon 2012